

## SOPRANA OVAL

table lamp, TC-(D,H,T,Q)SE, oval, white shade, max. 60W

Article number	155841
Product family	Soprana Oval
Feed-in capability	No
Lampholder / Socket	E27
Number of light sources	1
Lamp included	No
Length	32 cm
Width	17.5 cm
Height	56 cm
Net weight	1.516 kg
Gross weight	2.516 kg
Voltage	230V ~50Hz
Max. wattage	60 Watt
Protection class	II
Energy efficiency class	A++
Catalogue page	BIG WHITE 2018: 83
Light distribution type 1	direct - indirect
Light distribution type 2	symetrically
Lamp	A60
Colour	white
Form	oval
Material	Steel/textile
Type of plug	Euro plug and mains plug
Way of mounting	Portable

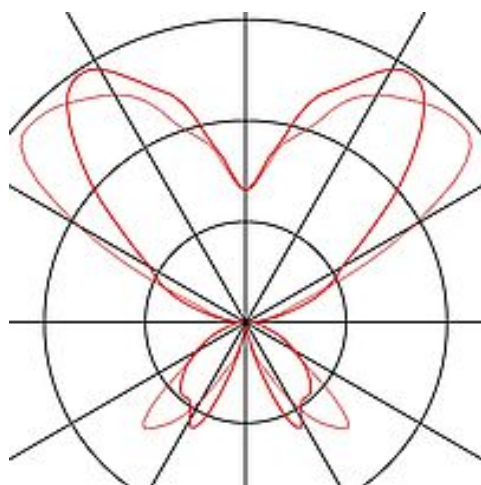
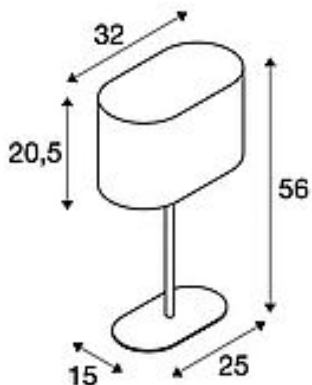

#### Articles of this series

- |        |  |
|--------|--|
| 155840 | SOPRANA OVAL, table lamp, A60, oval, black shade, max. 60W                 |
| 155850 | SOPRANA OVAL SL-1, floor stand, A60, oval, black shade, max. 60W           |
| 155851 | SOPRANA OVAL SL-1, floor stand, A60, oval, white shade, max. 60W           |
| 155860 | SOPRANA OVAL WL-1, wall light, A60, oval, black shade, max. 60W            |
| 155861 | SOPRANA OVAL WL-1, wall light, TC-(D,H,T,Q)SE, oval, white shade, max. 60W |
| 155870 | TRIADEM, pendant, triple-headed, A60, black shade, max. 180W               |
| 155871 | TRIADEM, pendant, triple-headed, A60, white shade, max. 180W               |

With our SOPRANA OVAL family we offer modern lights with appealing design available as table, floor and wall lamps. Thanks to the incorporated E27 lamp holders, all variants throughout the series can be equipped with incandescent, energy-saving and LED lamps. The connection is made directly to 230V mains. Regardless of the shade colour, all metallic parts of this series offer an attractive chrome finish. This luminaire is compatible with bulbs of the energy classes: E - A++

#### Notes

---



---



---