





PLASTRA

wall light, double-headed, LED GU10 111mm, square, up/down, white plaster, B/H/T 14/24.5/17 cm

Article number	148064
Feed-in capability	No
Lampholder / Socket	GU10
Number of light sources	2
Lamp included	No
Width	14 cm
Height	24.5 cm
Depth	17 cm
Net weight	4.067 kg
Gross weight	4.742 kg
Voltage	220-240V ~50/60Hz
Max. wattage	17 Watt
Protection class	I
Energy efficiency class	A++
Lamp	LED GU10 51mm
Colour	white
Form	square
Light distribution type 1	direct - indirect
Material	Plaster/steel

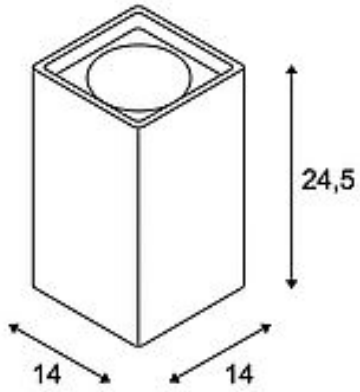

With the PLASTRA LED plaster light, you have a highly-individual ceiling light with a puristic design. Prepared to accept a QPAR111 LED lamp, it is ready for direct connection to the 230V mains supply. The sandpaper included as part of the delivery is used to clean the surfaces. After priming, the luminaire can be painted with wall paint as desired. The PLASTRA product family impresses with its wide range of application and design possibilities.



Notes
