

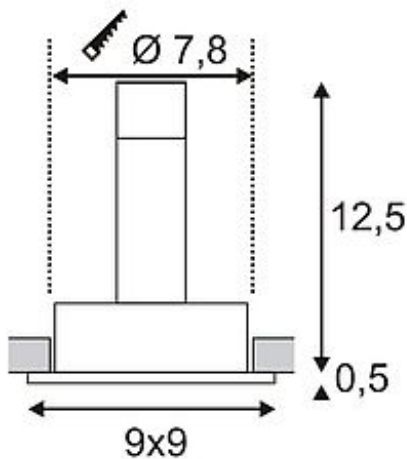

NEW TRIA I GU10 downlight

square, brushed aluminium, max. 50W, incl. clip springs

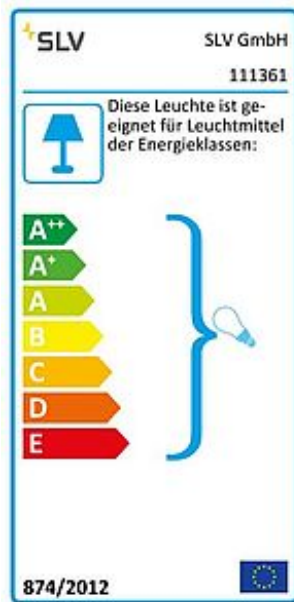

Article number	111361
Feed-in capability	No
LBS code	QPAR51
Lampholder / Socket	GU10
Number of light sources	1
Lamp included	No
Installation diameter	7.8 cm
Installation depth	12.5 cm
Tilt range	30 Degree
Rotation range	360 Degree
Length	9 cm
Width	9 cm
Height	11 cm
Net weight	0.171 kg
Gross weight	0.216 kg
Voltage	230 Volts
Max. wattage	50 Watt
Protection class	II
Energy class luminaire	E -
Suitable for lamps from EEC	E
Suitable for lamps up to EEC	A++
Lamp	GU10 230V
Material	Aluminium
Colour	Aluminium brushed
Way of mounting	Recessed ceiling mounting
Light distribution type 1	direct