

LEUCOS[®]

You spot it from afar

2023

LEUCOS®

You spot it from afar

A long history of iconic pieces.

Timeline.

1962

Gill
design
Roberto Pamio



1968

Aella
design
Renato Toso &
Noti Massari



1971

Aghia
design
Roberto Pamio



1975

**Sierra &
Solimani**
design
Roberto Pamio &
Renato Toso

Redesign 1984
Roberto Pamio



1975

Febo
design
Roberto Pamio &
Renato Toso



1980

Alba
design
Roberto Pamio &
Renato Toso

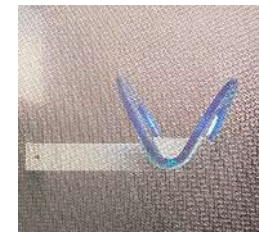

1982

Ventilla
design
Roberto Pamio &
Roberto Toso



Timeline.

1984

Dione
design
Roberto Pamio



1984

**Eta &
Van**
design
Roberto Pamio



1985

Formelle
1985 period of
boom in Formelle



1990

Laguna
design
Renato Tosi &
Noti Massari &
Associates with
G. Toso



1992

Vittoria
design
Renato Toso &
Noti Massari &
Associates



2007

Stacking
design
Rockwell Group



LEUCOS®

Timeline.

You spot it from afar

2019

Leucos
acquired by

Abramo
Manfrotto



JJ BIG



JJ BIG - Grip

2021

Aurelia
design
Patrick Jouin



Introduction of the
LED source

2021

Lightbody
T - S
design
Jörg Hugo



2023

Stacking
S120H S180H
design
Rockwell Group



2023

Stacking
S30V S60V S90V
design
Rockwell Group



2023

Aella 45
T - S
design
Toso&Massari



LEUCOS®

«My childhood memories led me to discover the timeless beauty of a LEUCOS. Falling in love with the brand's history and classic icons sparked a passion in me to modernize the industry and bring new life to its timeless classics.»

— Abramo Manfrotto

In the picture: Abramo Manfrotto and his father Lino Manfrotto, 1966

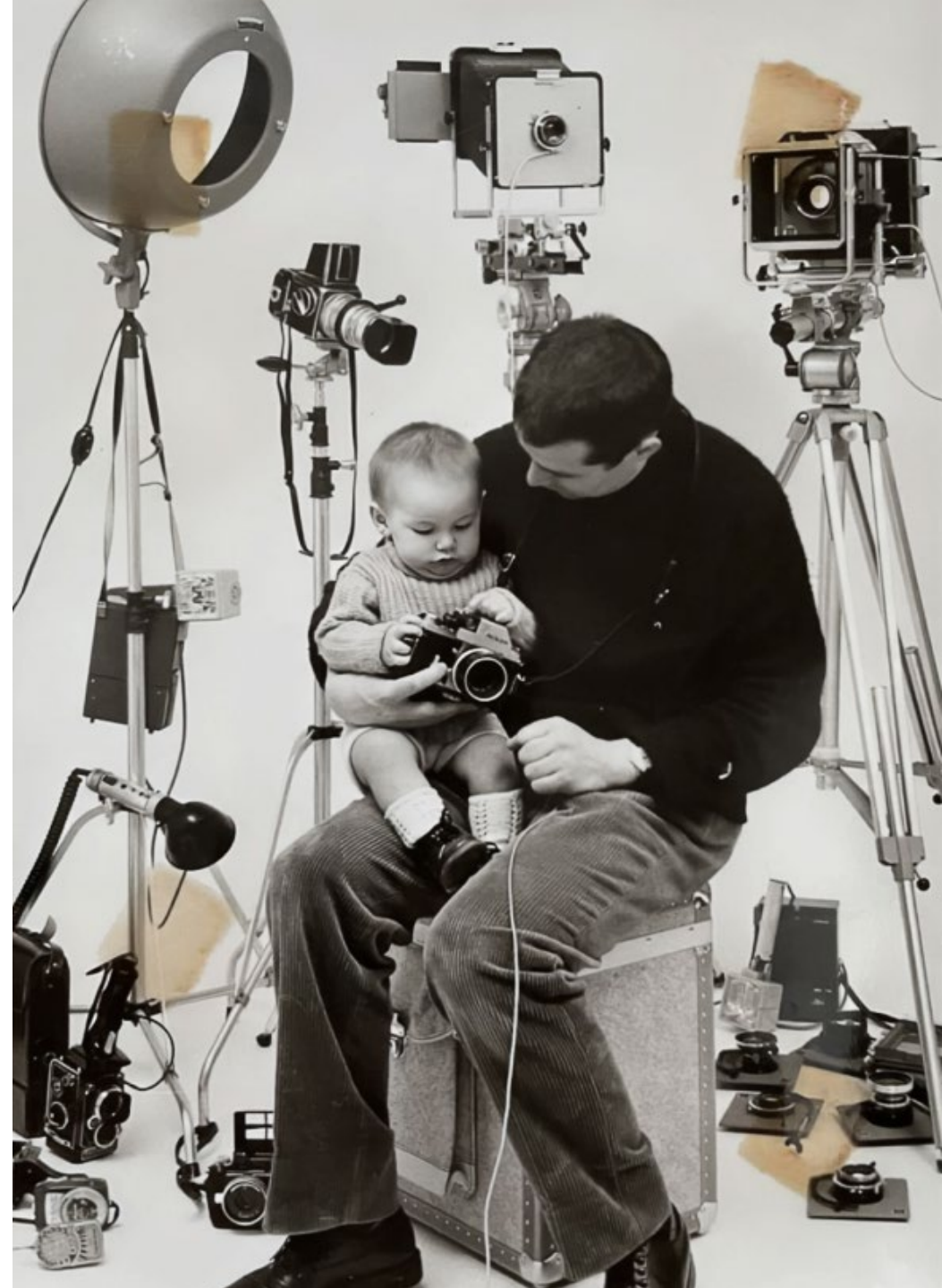

LEUCOS®

“Growing up as the son of the visionary entrepreneur and innovator behind the world-renowned Manfrotto, a manufacturer of professional camera and lighting equipment, I was drawn to the art of light in photography.

I always knew one day I would get into lighting, because from an early age I have been immersed in light: balanced, sublime, high-end professional photographic light – its ability to evoke emotions and shape moods captivated me.

Using the knowledge from the past and what we know today on innovation, business models, distribution, sustainability and bespoke solutions, I am confident that LEUCOS is the right partner to bring our clients vision to light”.

– *Abramo Manfrotto*

In the picture from left: Abramo Manfrotto's sister Lavinia, Abramo and his mother Elena.
Photo by Lino Manfrotto, 1970.

**if you must photograph
fresh pears,
take your studio under
the pear tree!**



*(you can, with equipment by
Manfrotto)*

Over sixty years of lighting history

LEUCOS was born in 1962 near Venice, where craftsmanship is synonymous with art. Since the beginning, we have been known for creating lamps of unmistakable quality and unparalleled beauty.

At LEUCOS, we inspire your imagination and push the boundaries of conventional thinking.

The handblown glass represents the local tradition, but behind every new project there is a global ambition.

With a deep passion for timeless beauty, we are continuously driven to innovate and elevate our modern-classics.



Our formula is a combination of design, materials, manufacturing techniques, technologies, and exceptional human resources.

We offer both standard products with a high degree of customization options and fully bespoke solutions.

Our mission is to cultivate value for our clients, partners, and company.

This drives us to produce beautiful, expertly crafted, dependable, efficient, and long-lasting products through innovation and simplification.

Our commitment to excellence shines in every product we create - **you spot it from afar.**



LEUCOS®

You spot it from afar

Timeless beauty made with passion
for innovation and bespoke solutions.
Modern classics that will endure
across generations.



Our mission is to cultivate value for our clients,
partners, and company.

We achieve this by producing beautiful, expertly crafted, dependable, efficient, and longlasting products through innovation and simplification.

LEUCOS®

You spot it from afar



Vision

Our insatiable curiosity and open-minded approach enables us to uncover innovative materials and new solutions.

Our vision will foster deeper emotional bonds between our customers and products, thereby ensuring the longevity and enduring beauty of our modern classics.

LEUCOS®

You spot it from afar

Passion



LEUCOS®

You spot it from afar

Timeless
Beauty



LEUCOS®

You spot it from afar

Curiosity

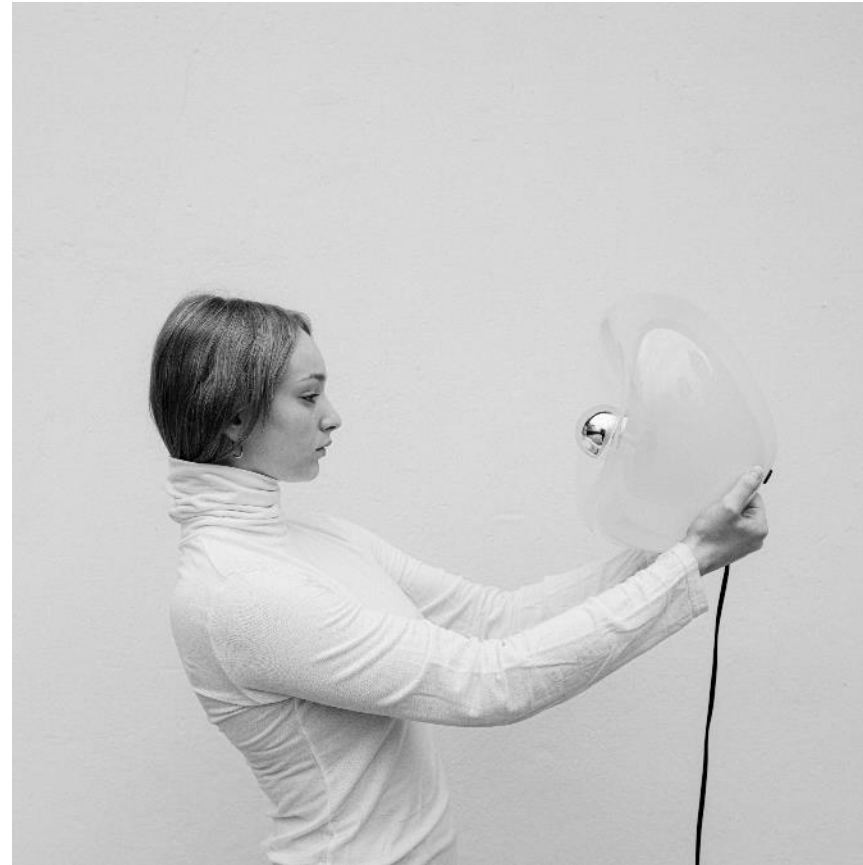

LEUCOS®

You spot it from afar

Innovation



Products Range 2023

Aurelia S45, Aurelia S Bold 22 upgraded

Patrick Jouin, 2021

Upgrades: single switch, new color finishes:

Diffuser: smoke-grey, shaded white, shaded burgundy, transparent water effect, blue water effect, transparent pulegoso with metal powder inclusion.

Structure: matte white, vintage brass, matte gunmetal

LEUCOS®

You spot it from afar



LEUCOS®

You spot it from afar



Product: Aurelia S45, Bold S22

Designer: Patrick Jouin

Typology: Suspension

Light source Aurelia S45: Direct: LED 1 X 11,6W 1531 lm (nominal) 3000K CRI≥90 Indirect: LED 1 X 14,4W 2450 lm (nominal) 3000K CRI≥90 or Direct: LED 1 X 11,6W 1471 lm (nominal) 2700K CRI≥90 Indirect: LED 1 X 14,4W 2360 lm (nominal) 2700K CRI≥90

Light source Aurelia S Bold 22: Direct: LED 1 X 11,6W 1531 lm (nominal) 3000K CRI≥90 Indirect: LED 1 X 5,8W 980 lm (nominal) 3000K CRI≥90 or Direct: LED 1 X 11,6W 1471 lm (nominal) 2700K CRI≥90 Indirect: LED 1 X 5,8W 944 lm (nominal) 2700K CRI≥90

Dimmer: Push-dim; 0/1-10V; Dali

Materials (diffuser/structure): handblown glass/metal

Color finishes

Diffuser: smoke-grey, shaded white, shaded burgundy, transparent water effect, blue water effect, transparent pulegoso with metal powder inclusion.

Structure: matte white, vintage brass, matte gunmetal

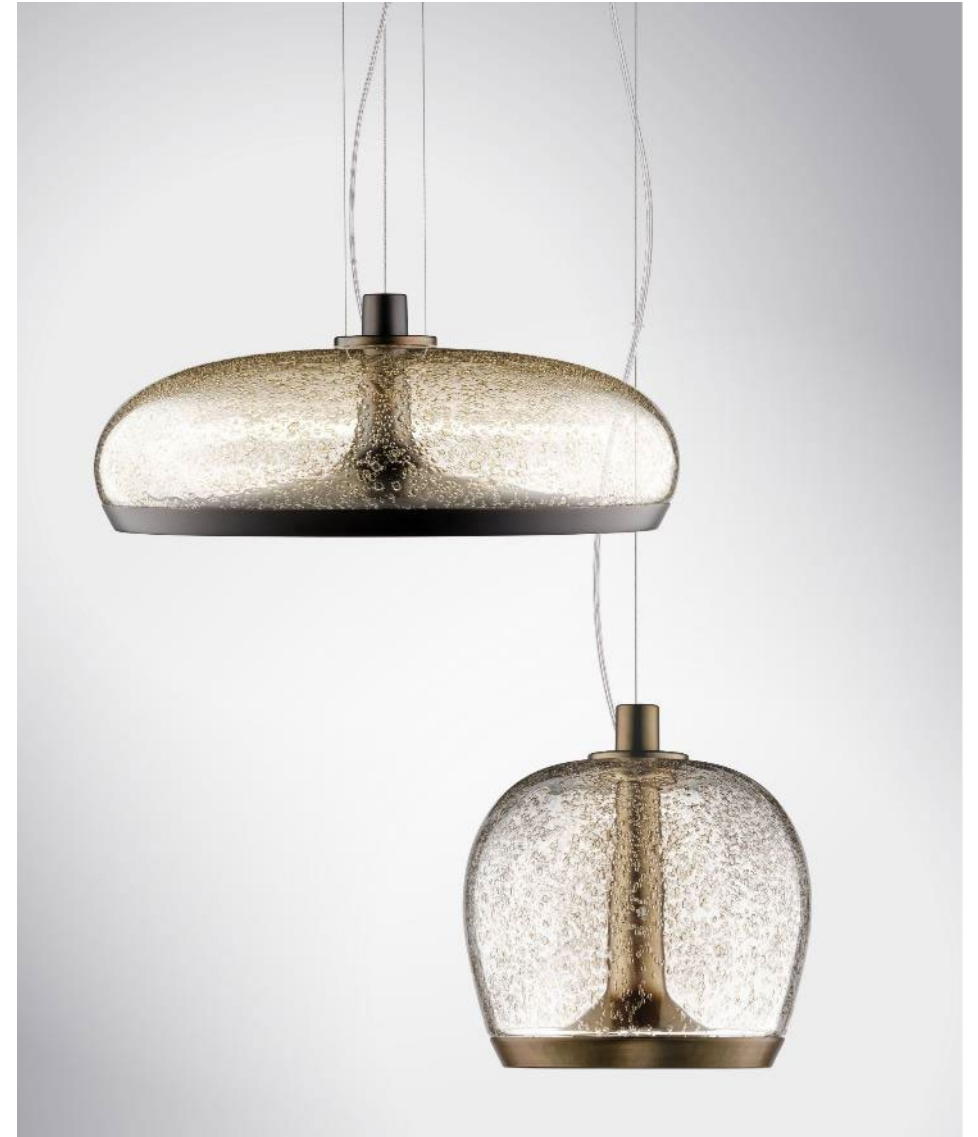

Aurelia S 45

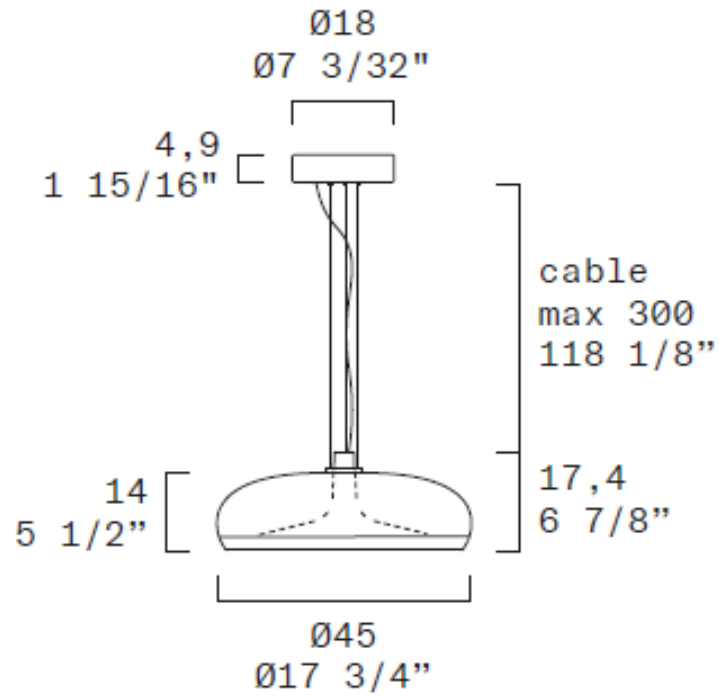

Aurelia Bold S 22

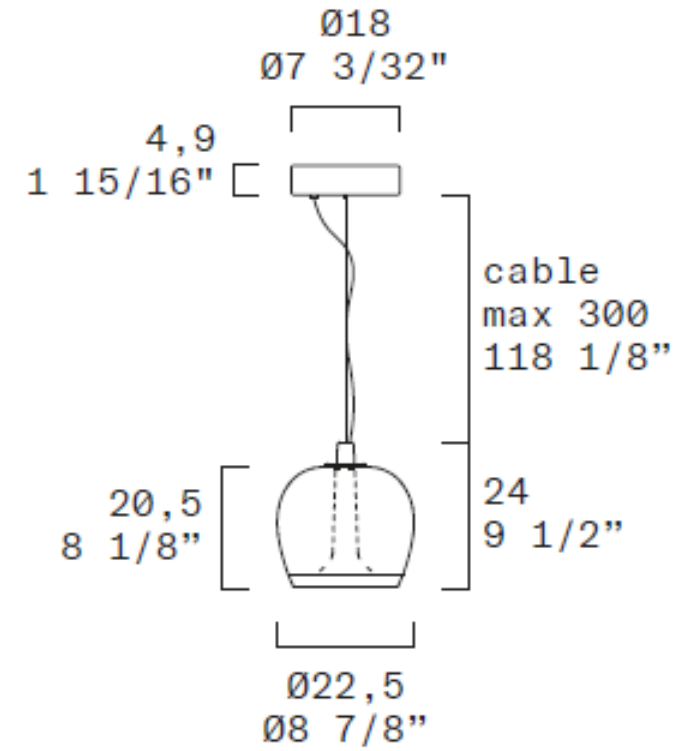

LEUCOS®

You spot it from afar



LEUCOS®



LEUCOS®



You spot it from afar

LEUCOS®

You spot it from afar



LEUCOS®

You spot it from afar



LEUCOS®

You spot it from afar



LEUCOS[®]

You spot it from afar



LEUCOS®

You spot it from afar



LEUCOS®

You spot it from afar



LEUCOS®

You spot it from afar



LEUCOS®

You spot it from afar



LEUCOS®

You spot it from afar

Stacking S120 H, S180 H

David Rockwell, 2023

LEUCOS®

You spot it from afar



LEUCOS®

You spot it from afar

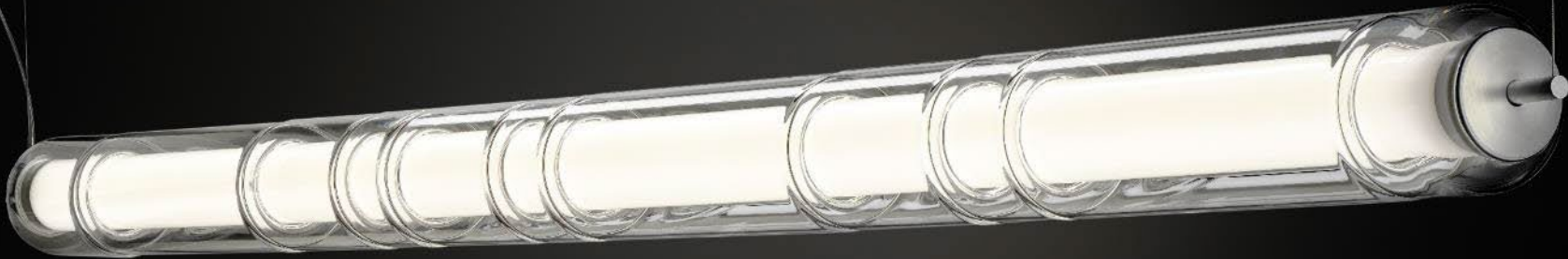

LEUCOS®

You spot it from afar



LEUCOS®

You spot it from afar



Product: Stacking S 180 H, Stacking S 120 H

Designer: David Rockwell

Typology: Suspension

Light source S 180: 5 X LED STRIP 24V 43,75W (total) 5031 lm (nominal) 3000K CRI≥90 or 5 X LED STRIP 24V 43,75W (total) 4812 lm (nominal) 2700K CRI≥90

Light source S 120: 5 X LED STRIP 24V 28,75W (total) 3306 lm (nominal) 3000K CRI≥90 or 5 X LED STRIP 24V 28,75W (total) 3162 lm (nominal) 2700K CRI≥90

Dimmer: Push-dim; 0/1-10V; Dali

Materials (diffuser / structure): blown borosilicate glass / metal

Color finishes (diffuser / structure): Transparent / anodized silver



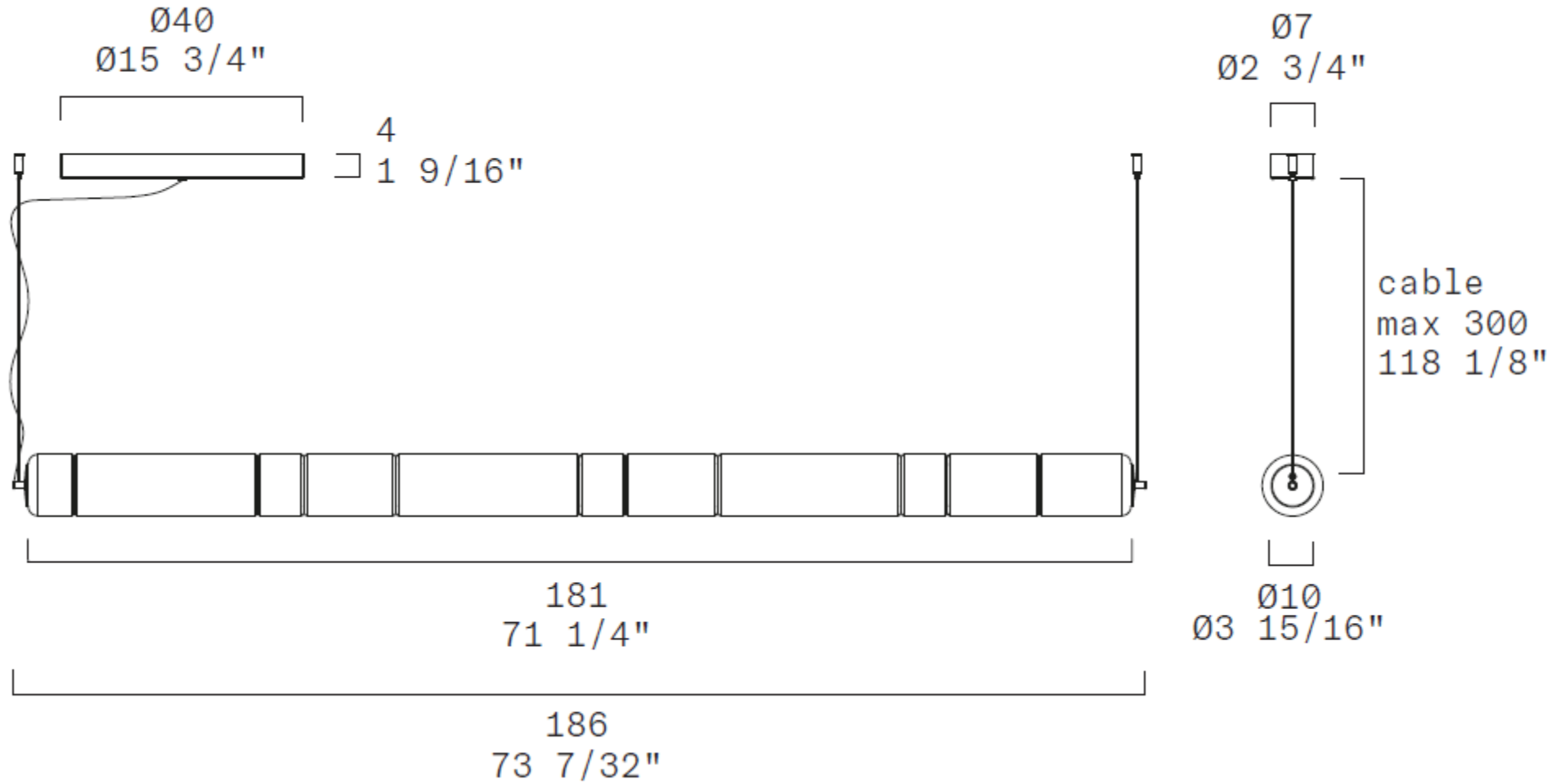

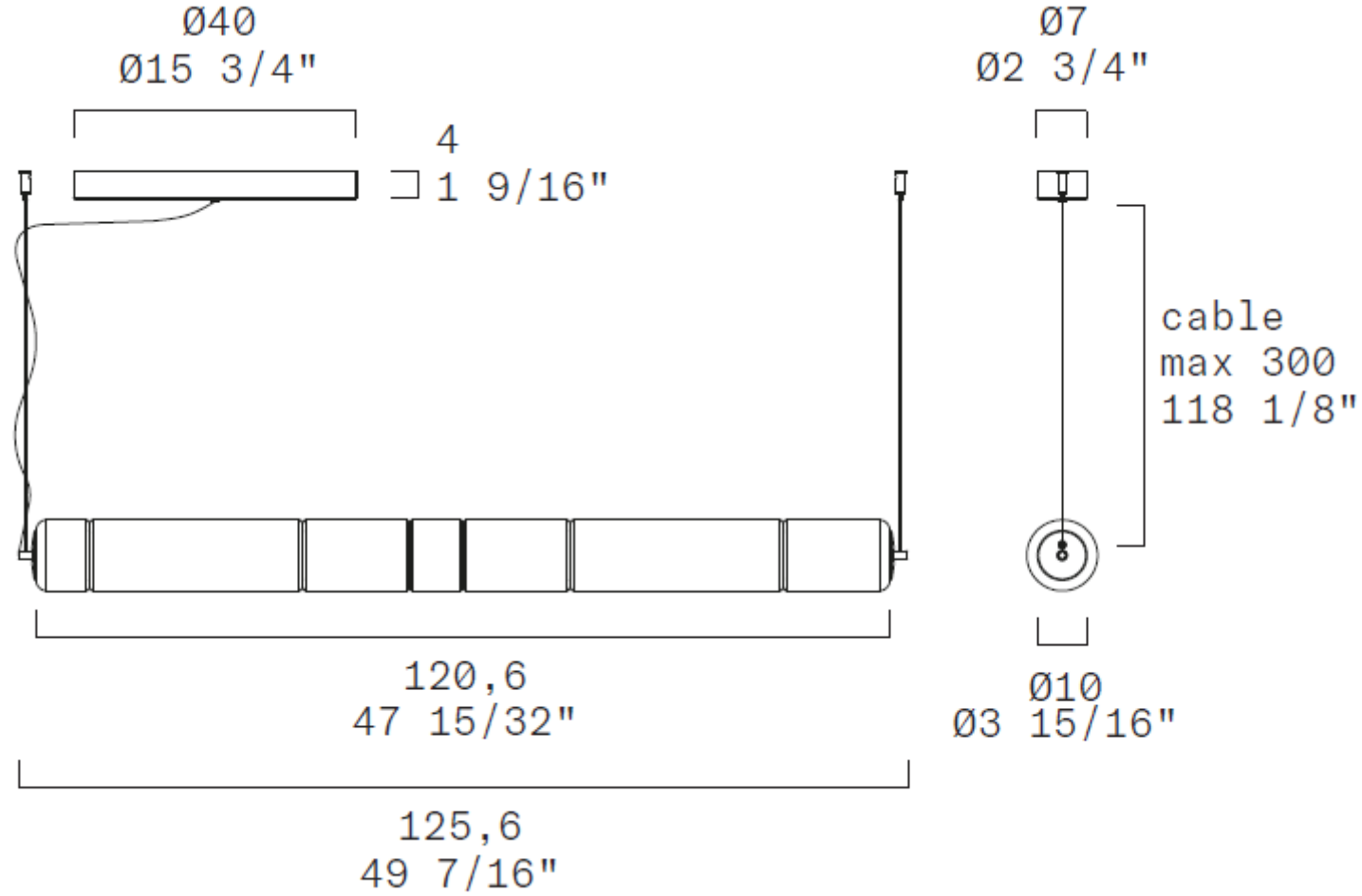

LEUCOS®

You spot it from afar



LEUCOS®

You spot it from afar



LEUCOS®

You spot it from afar



LEUCOS[®]

Stacking S30 V, S60 V, S90 V

David Rockwell, 2023

LEUCOS®

You spot it from afar



LEUCOS®

You spot it from afar



LEUCOS®

You spot it from afar



Product: Stacking S 30 V, S 60 V, S 90 V

Designer: David Rockwell

Typology: Suspension

Light source S 30: 5 X LED STRIP 24V 6,25W (total) 718 lm (nominal) 3000K CRI≥90 or 5 X LED STRIP 24V 6,25W (total) 687 lm (nominal) 2700K CRI≥90

Light source S 60: 5 X LED STRIP 24V 13,75W (total) 1581 lm (nominal) 3000K CRI≥90 or 5 X LED STRIP 24V 13,75W (total) 1512 lm (nominal) 2700K CRI≥90

Light source S 90: 5 X LED STRIP 24V 21,25W (total) 2443 lm (nominal) 3000K CRI≥90 Or 5 X LED STRIP 24V 21,25W (total) 2337 lm (nominal) 2700K CRI≥90

Dimmer: Push-dim; 0/1-10V; Dali

Materials (diffuser/structure): blown borosilicate glass/metal

Color finishes (diffuser/structure): Transparent/anodized silver



Stacking S 30 V

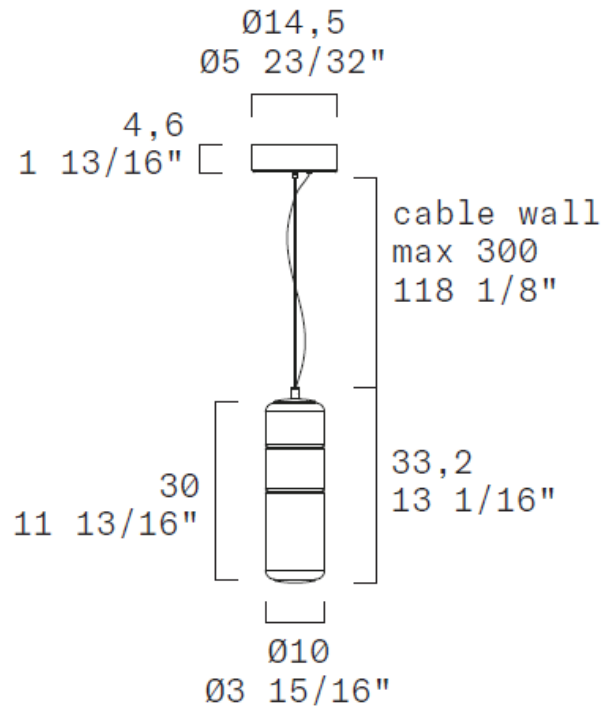

Stacking S 60 V

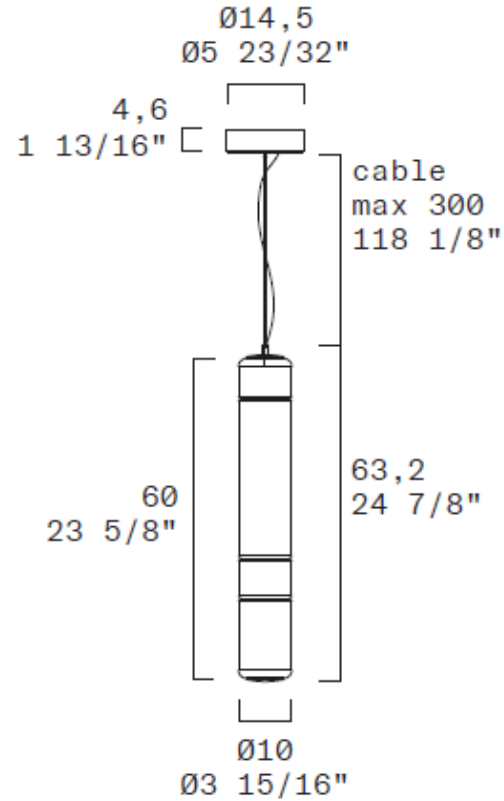

Stacking S 90 V

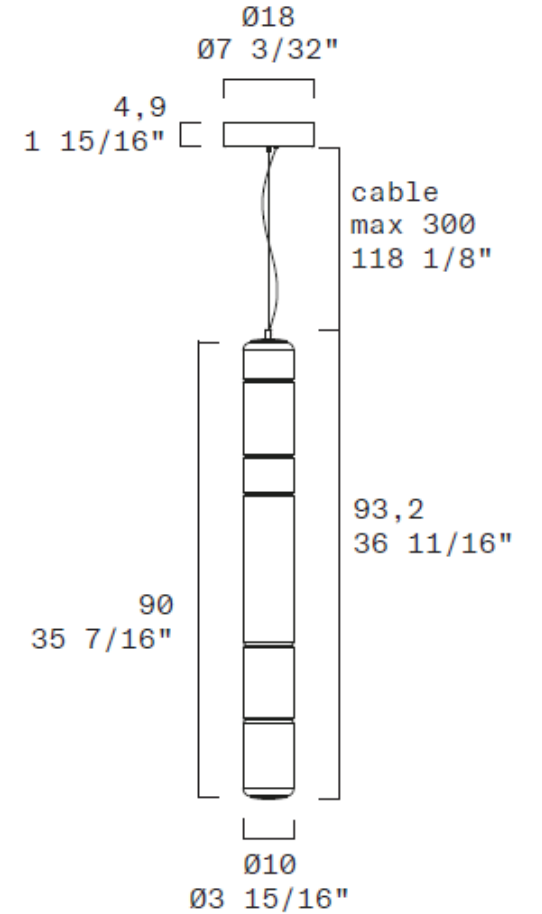

Stacking S120 H NAKED,
Stacking S180 H NAKED

David Rockwell, 2023

LEUCOS®

You spot it from afar

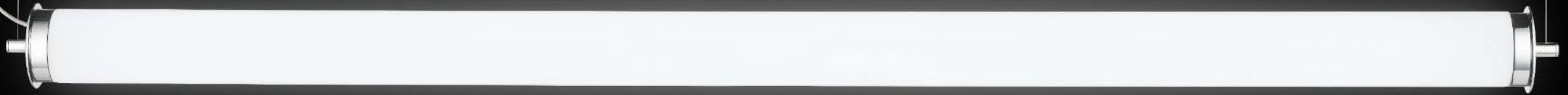

LEUCOS®

You spot it from afar



LEUCOS®

You spot it from afar



Product: Stacking S 180 H NAKED, Stacking S 120 H NAKED

Designer: David Rockwell, 2023

Typology: Suspension

Light source S 180 NAKED:

5 X LED STRIP 24V 43,75W (total) CRI≥90 :

- 5031 lm (nominal) 3000K
- 4812 lm (nominal) 2700K

Light source S 120 NAKED:

5 X LED STRIP 24V 28,75W (total) CRI≥90

- 3306 lm (nominal) 3000K
- 3162 lm (nominal) 2700K

Dimmer: Push-dim; 0/1-10V; Dali

Materials (diffuser / structure): PMMA / metal

Color finishes (diffuser / structure): White / anodized silver

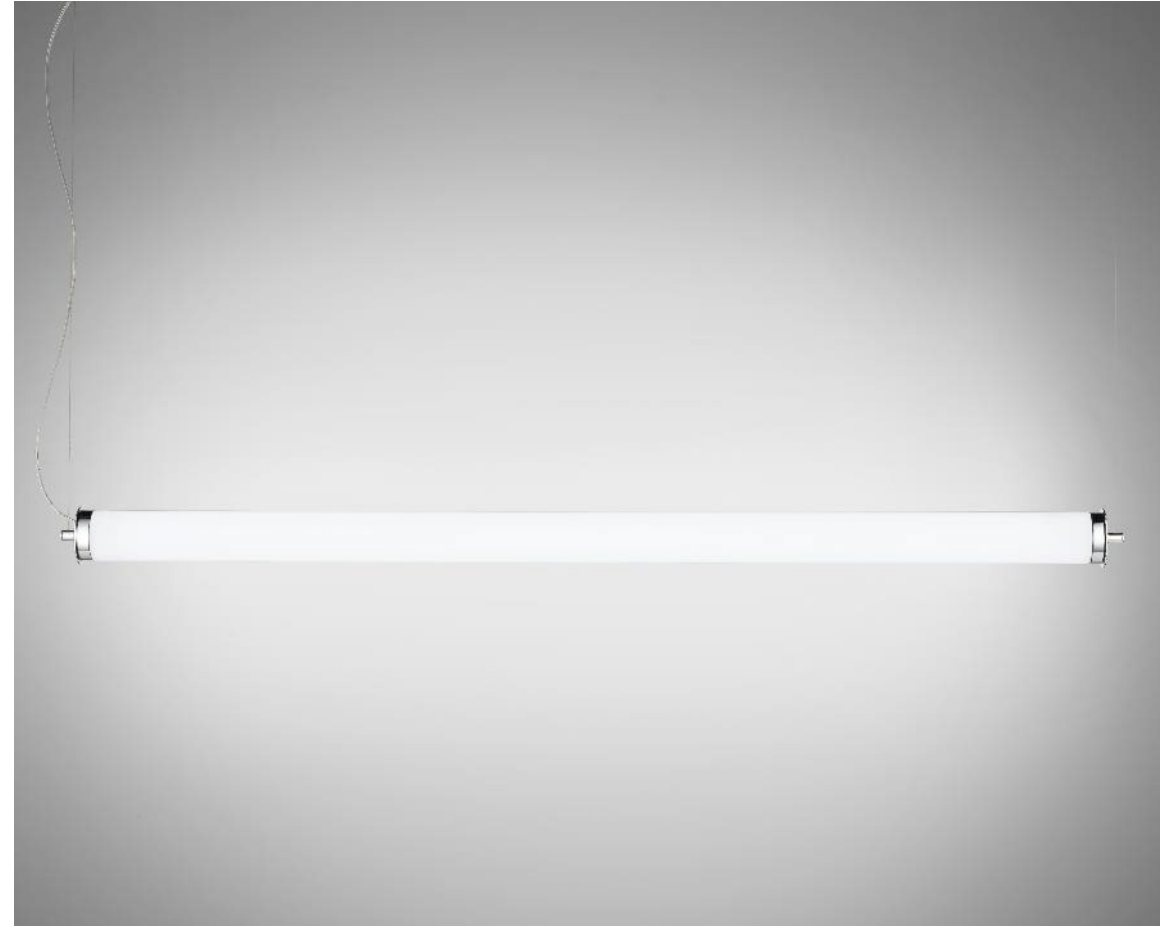

Stacking S30 V NAKED,
S60 V NAKED, S90 V NAKED

David Rockwell, 2023

LEUCOS®

You spot it from afar



LEUCOS®



You spot it from afar

Product: Stacking S 30 V NAKED, S 60 V NAKED, S 90 V NAKED

Designer: David Rockwell, 2023

Typology: Suspension

Light source S 30 NAKED:

5 X LED STRIP 24V 6,25W (total) CRI≥90

- 718 lm (nominal) 3000K
- 687 lm (nominal) 2700K

Light source S 60 NAKED:

5 X LED STRIP 24V 13,75W (total) CRI≥90

- 1581 lm (nominal) 3000K
- 1512 lm (nominal) 2700K

Light source S 90 NAKED:

5 X LED STRIP 24V 21,25W (total) CRI≥90

- 2443 lm (nominal) 3000K
- 2337 lm (nominal) 2700K

Dimmer: Push-dim; 0/1-10V; Dali

Materials (diffuser/structure): PMMA/metal

Color finishes (diffuser/structure): White/anodized silver



LEUCOS®

You spot it from afar

Stacking B TR, C TR, D TR

Rockwell Group, 2007

LEUCOS[®]

You spot it from afar



Product: Stacking B TR, CTR, D TR

Designer: Rockwell Group, 2007

Typology: Floor

Light source: GU10 4 x 7W Retrofit LED (4 x max 50W Halogen Bulb)

Dimmer: dimmer on cord

Materials (diffuser/structure): blown glass/metal

Color finishes (diffuser/structure):

Stacking B TR: Smoke Grey, White, Smoke Grey, White, Mirror / Chrome

Stacking C TR: Smoke Grey, White, Amber, Tobacco, White, Amber / Gold

Stacking D TR: White, Gold, Transparent Tobacco, White, Gold, Black / Gold



Stacking B TR

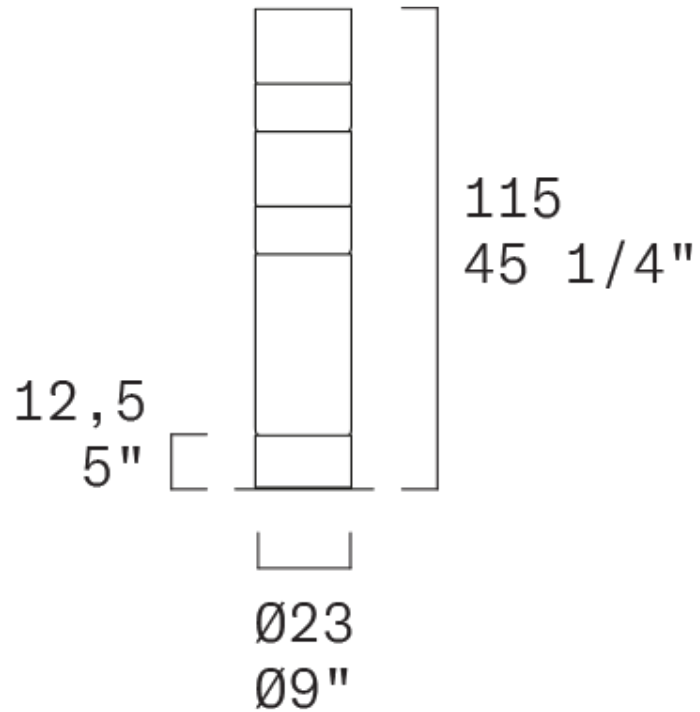

Stacking C TR

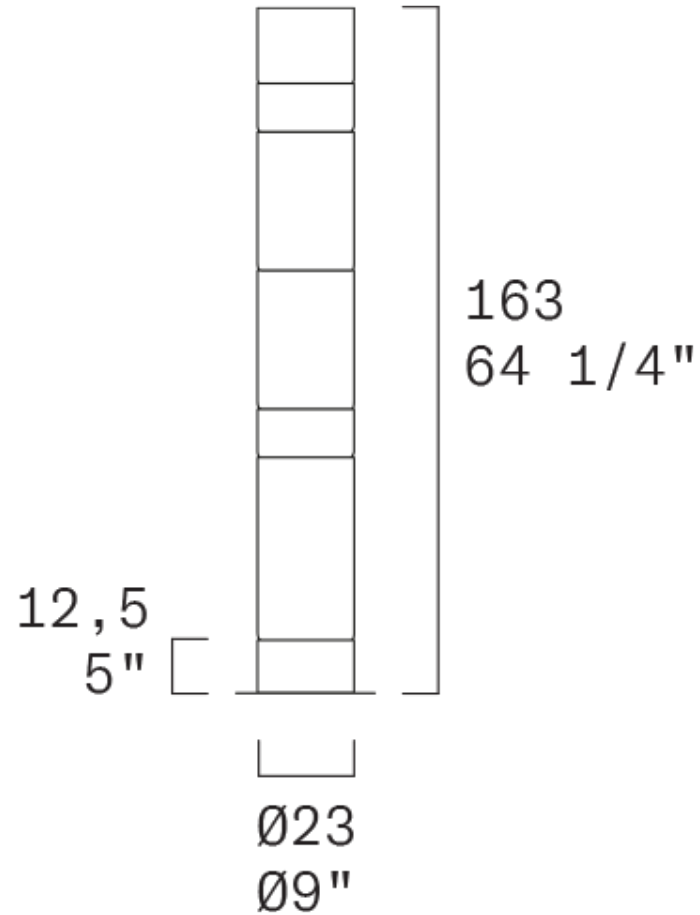

Stacking D TR

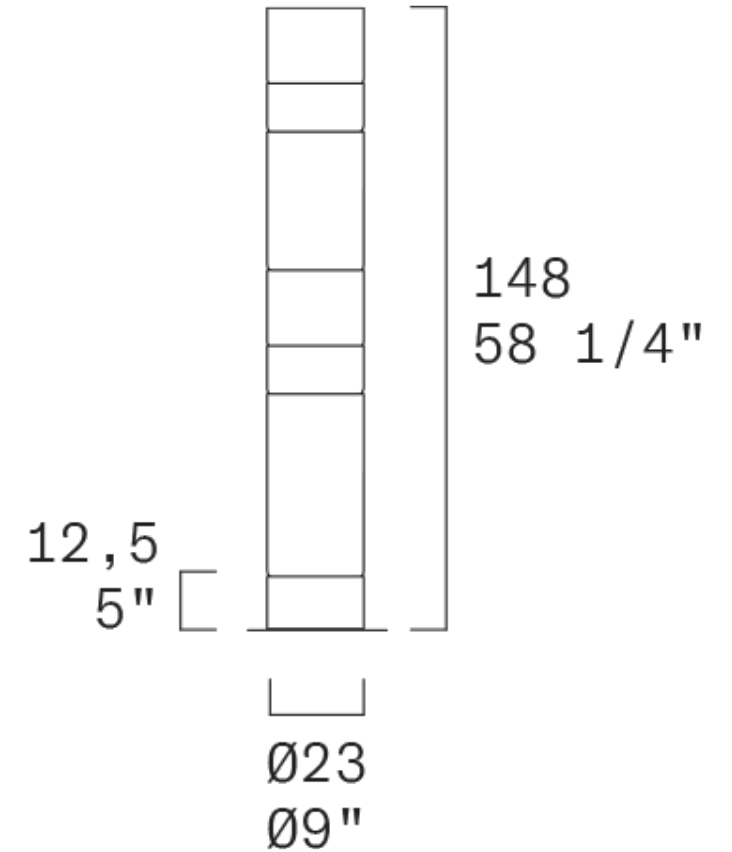

LEUCOS®

You spot it from afar



LEUCOS®



You spot it from afar

LEUCOS®

You spot it from afar



New Aella T45, S45 Aella T30, T54 - Aella S30, S54 upgraded

Toso&Massari, 1968

Upgrades: new size, sizes 30 and 54 «reproportioned», introduction of long neck structure for the suspension versions, upgraded electronics and new color finishes

LEUCOS®

You spot it from afar



LEUCOS®

You spot it from afar



Product: Aella T30

Designer: Toso & Massari, 1968

Typology: Table

Light source:

LED 1 X 11,7W 1568lm (nominal) 3000K CRI≥90 or
LED 1 X 11,7W 1506lm (nominal) 2700K CRI≥90

Dimmer: Dimmer on cord

Materials (diffuser/structure): handblown glass/metal

Color finishes

Structure: matte white, matte black, matte gold

Diffuser: transparent with white spot, transparent pulegoso with metal powder inclusion, shaded burgundy, shaded pink



Product: Aella T45

Designer: Toso & Massari, 1968

Typology: Table

Light source:

LED 1 X 16,8W 2556lm (nominal) 3000K CRI≥90 or
LED 1 X 16,8W 2456lm (nominal) 2700K CRI≥90

Dimmer: Dimmer on cord

Materials (diffuser/structure): handblown glass/metal

Color finishes

Structure: matte white, matte black, matte gold

Diffuser: transparent with white spot, transparent pulegoso
with metal powder inclusion, shaded white, white shaded pink



LEUCOS®

You spot it from afar

Product: Aella T54

Designer: Toso & Massari, 1968

Typology: Table

Light source:

LED 1 X 26,7W 3944lm (nominal) 3000K CRI≥90 or
LED 1 X 26,7W 3791lm (nominal) 2700K CRI≥90

Dimmer: Dimmer on cord

Materials (diffuser/structure): handblown glass/metal

Color finishes

Structure: matte white, matte black, matte gold

Diffuser: transparent with white spot, shaded burgundy



Aella T 30

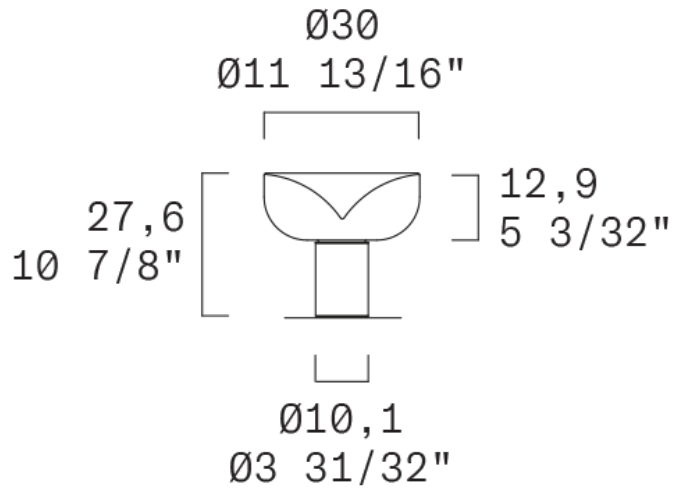

Aella T 45

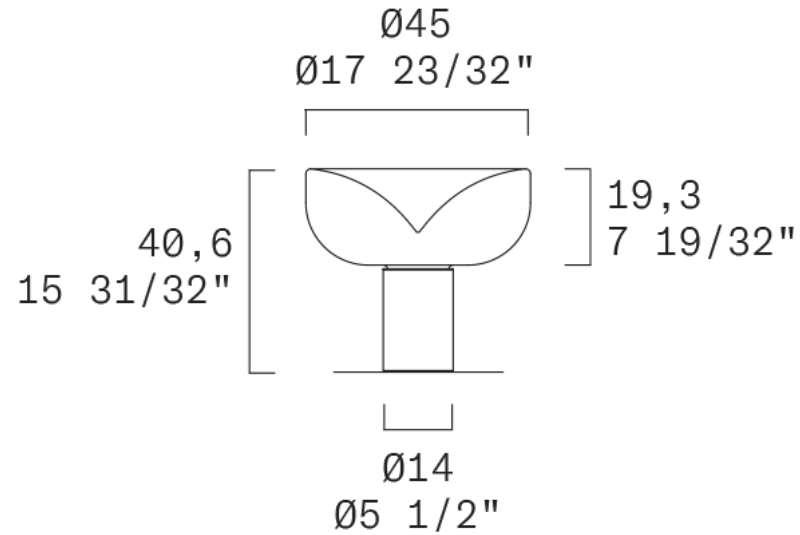

Aella T 54

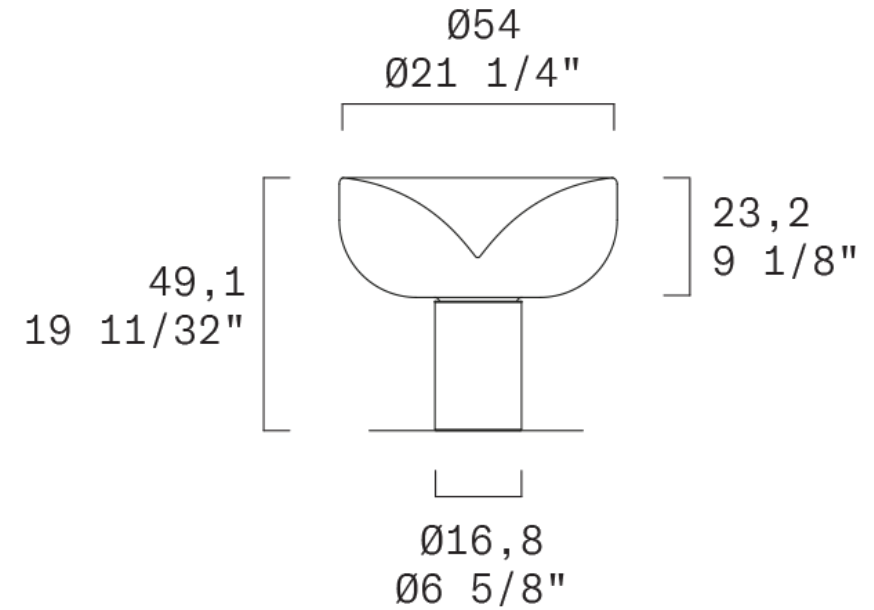

LEUCOS®

You spot it from afar



LEUCOS®

You spot it from afar



Product: Aella S 30

Designer: Toso & Massari, 1968

Typology: Pendant

Light source:

LED 1 X 11,7W 1568lm (nominal) 3000K CRI≥90or

LED 1 X 11,7W 1506lm (nominal) 2700K CRI≥90

Control: Push-dim; 0/1-10V; Dali

Materials (diffuser/structure): handblown glass/metal

Color finishes

Structure: matte white, matte black, matte gold

Diffuser: transparent with white spot, transparent pulegoso with metal powder inclusion, shaded burgundy, shaded pink



LEUCOS®

You spot it from afar

Product: Aella S 45

Designer: Toso & Massari, 1968

Typology: Pendant

Light source:

LED 1 X 16,8W 2556lm (nominal) 3000K CRI≥90 or
LED 1 X 16,8W 2456lm (nominal) 2700K CRI≥90

Control: Push-dim; 0/1-10V; Dali

Materials (diffuser/structure): handblown glass/metal

Color finishes

Structure: matte white, matte black, matte gold

Diffuser: transparent with white spot, transparent pulegoso with metal powder inclusion, shaded white, white shaded pink



LEUCOS®

You spot it from afar

Product: Aella S 54

Designer: Toso & Massari, 1968

Typology: Pendant

Light source:

LED 1 X 26,7W 3944lm (nominal) 3000K CRI≥90 or
LED 1 X 26,7W 3791lm (nominal) 2700K CRI≥90

Control: Push-dim; 0/1-10V; Dali

Materials (diffuser/structure): handblown glass/metal

Color finishes

Structure: matte white, matte black, matte gold

Diffuser: transparent with white spot, shaded burgundy



LEUCOS®

Aella S 30

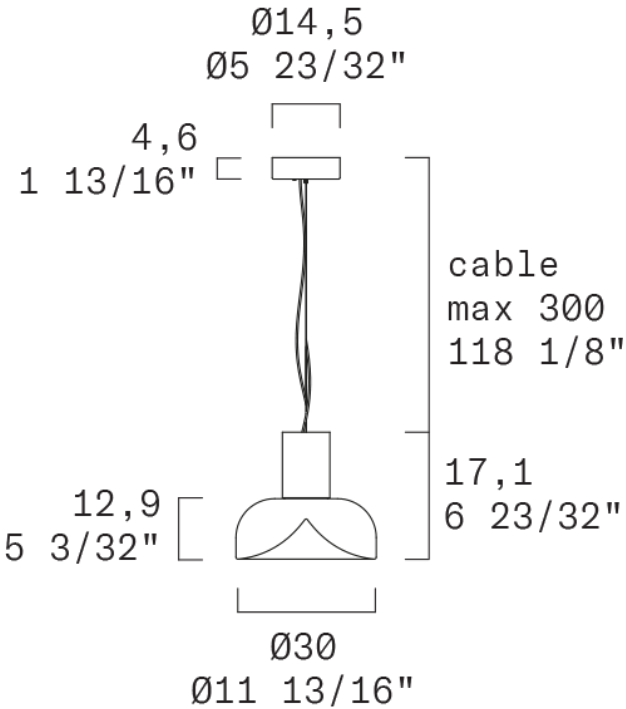

Aella S 45

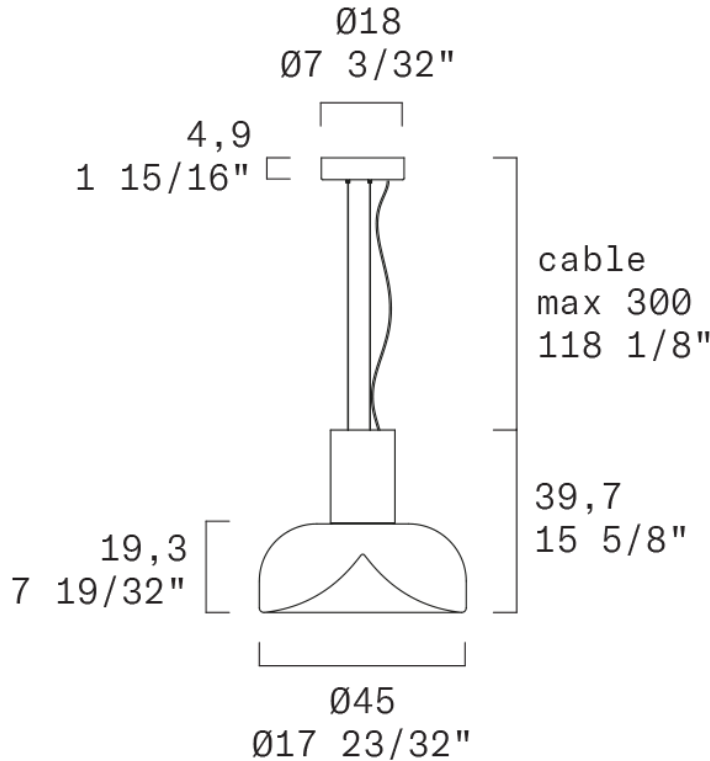

Aella S 54

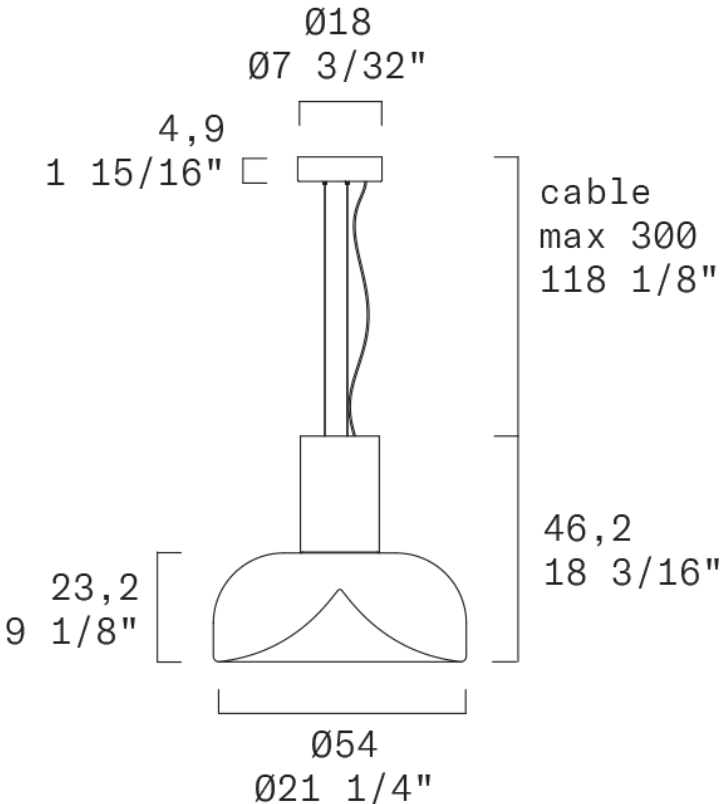

LEUCOS®

You spot it from afar

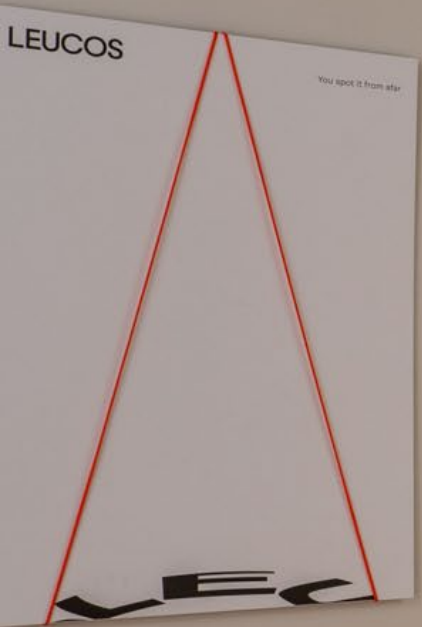



LEUCOS®

You spot it from afar



Lightbody T, Lightbody S upgraded

Jörg Hugo, 2021

Upgrades: one size for both table and suspension version, new color finishes

LEUCOS®

You spot it from afar



LEUCOS®

You spot it from afar

Product: Lightbody T, Lightbody S

Designer: Jörg Hugo

Typology: Table and suspension

Light source

Lightbody T: E27 1 x 10W Retrofit LED (1 x max 43W Halogen Bulb)

Light source Lightbody S: E27 1 x 10W Retrofit LED (1 x max 43W Halogen Bulb)

Dimmer: Dimmer on cord or On-off (Lightbody T)

Materials (diffuser/structure): handblown glass/metal

Color finishes

Diffuser: Transparent, transparent with white satin finish, shaded burgundy, shaded white, shaded pink.



Lightbody T

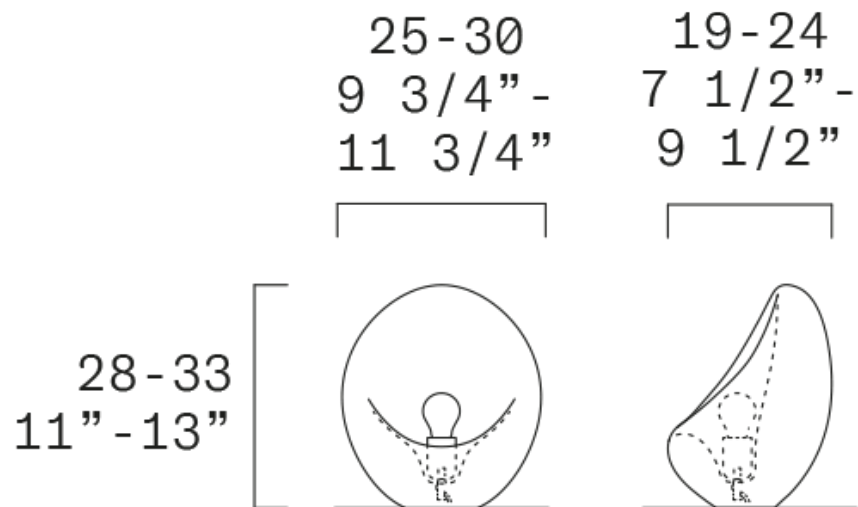

Lightbody S

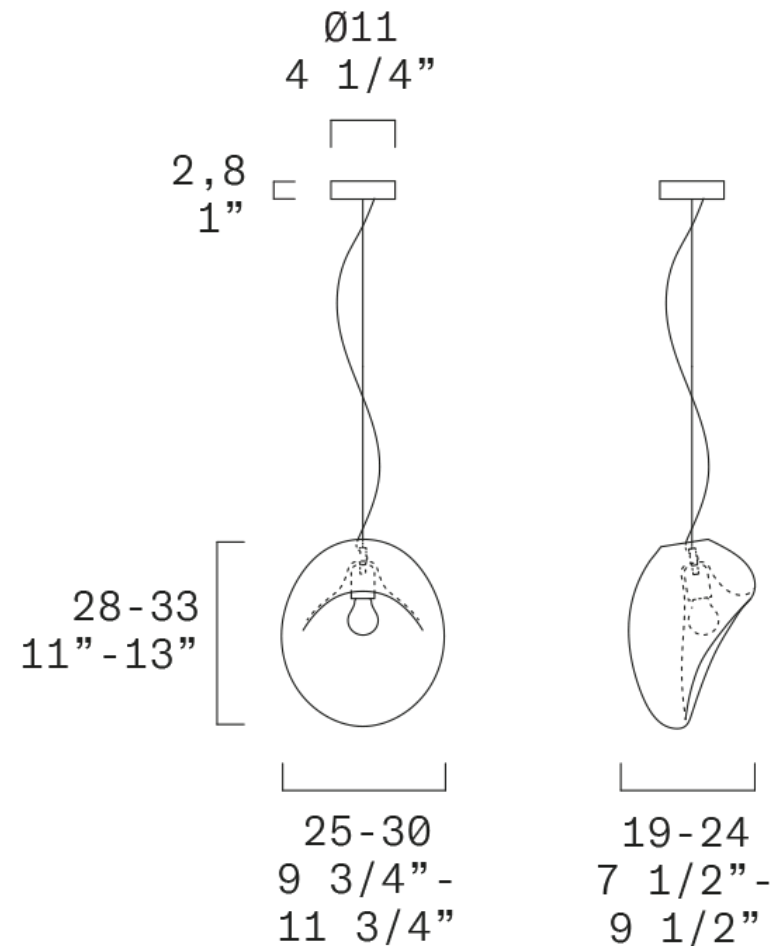

LEUCOS®

You spot it from afar



LEUCOS®

You spot it from afar

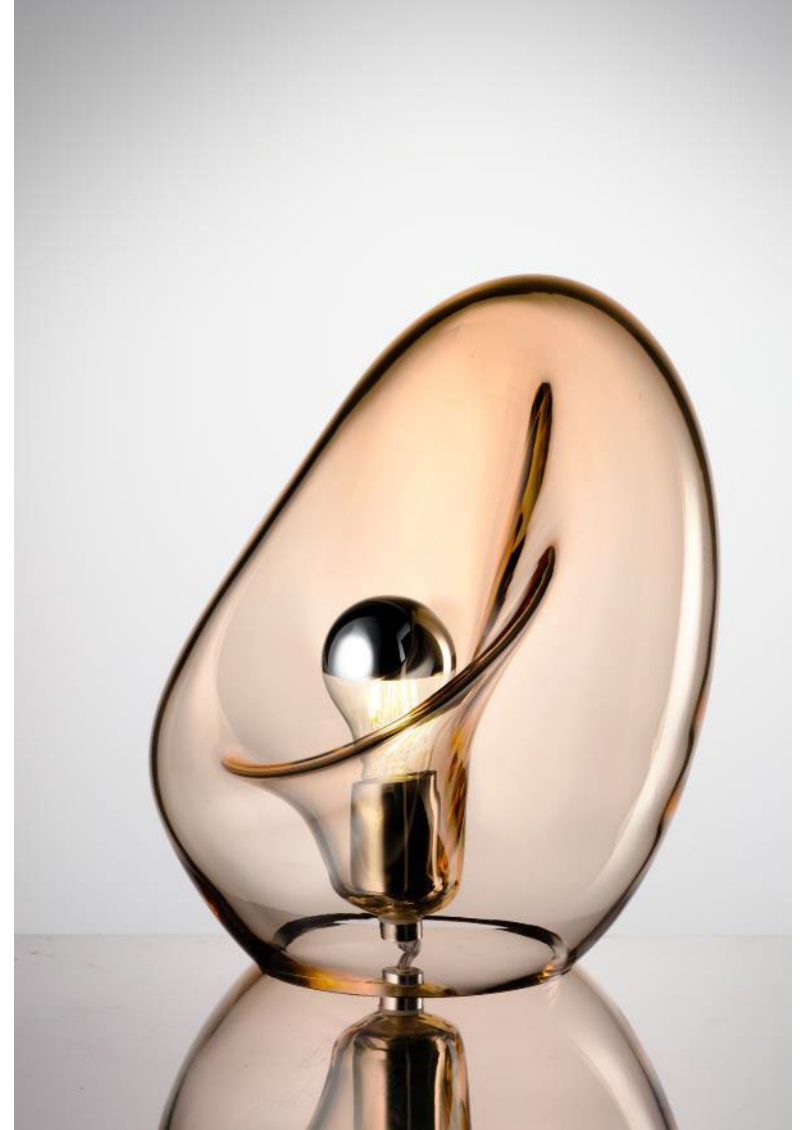

LEUCOS®

You spot it from afar



LEUCOS®

You spot it from afar

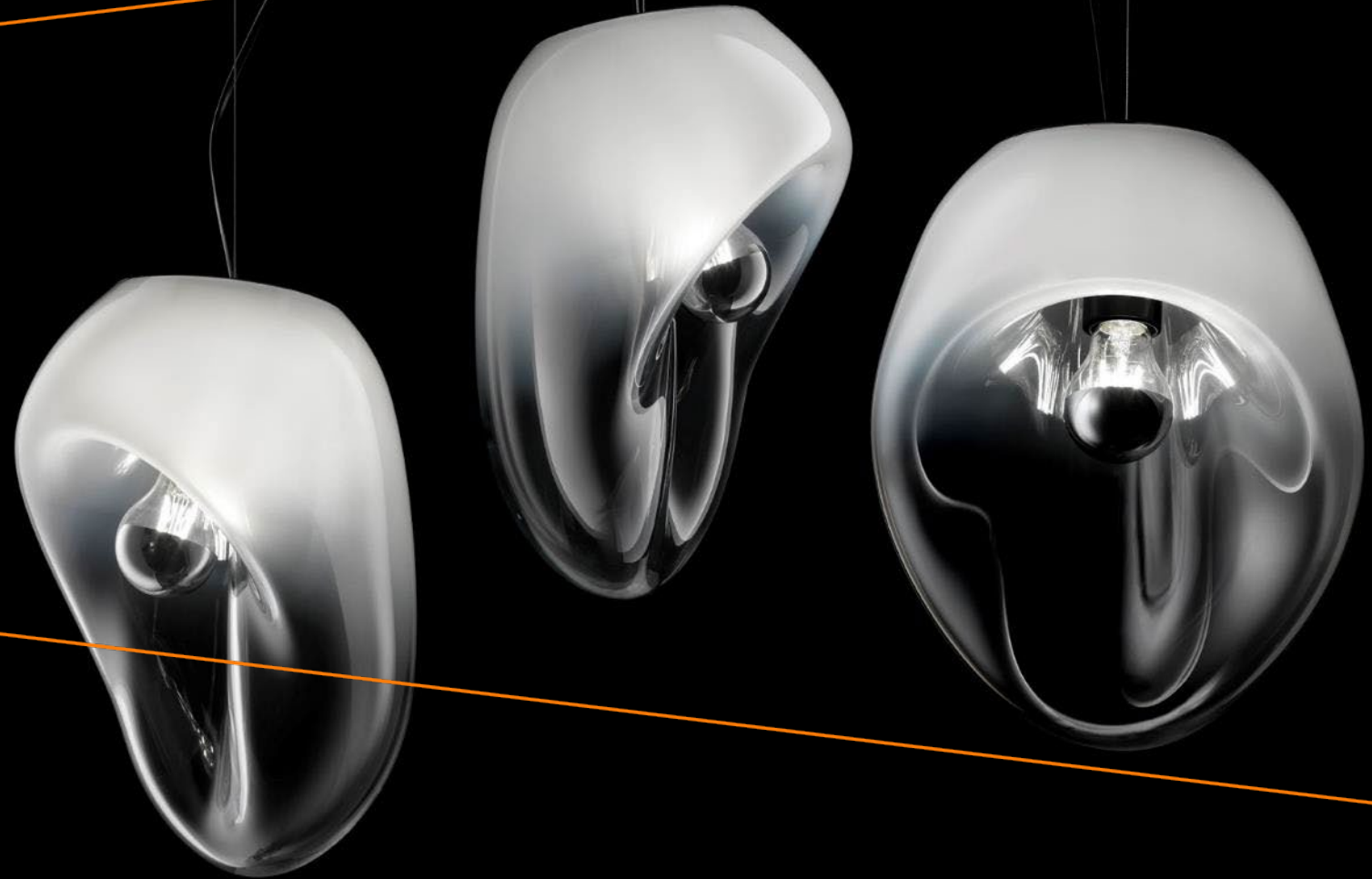

LEUCOS®

You spot it from afar



LEUCOS®

You spot it from afar

Ether S, Ether S 90, Ether S 150

Patrick Jouin, 2006

LEUCOS®

You spot it from afar

Product: Ether

Designer: Patrick Jouin

Type: Suspension

Light source: GU10 5 x 7W Retrofit LED

Dimmer: Dimmer on cord

Materials (diffuser / structure): Borosilicate blown glass / polished steel

Color finishes

Diffuser: Transparent

Structure: Polished steel



LEUCOS®

Product: Ether S 90

Designer: Patrick Jouin

Type: Suspension

Light source: G53 4 x 15W Retrofit LED
or
G53 4 x 15W Retrofit LED + GU5,3 1 x 8W Retrofit LED
RGB 660lm

Materials (diffuser / structure): Borosilicate blown
glass / polished steel

Color finishes

Diffuser: Transparent

Structure: Polished steel

Note: GU5,3 LED with RGB + Remote control (usable
until 5m)



LEUCOS®

Product: Ether S 150

Designer: Patrick Jouin

Type: Suspension

Light source: G53 4 x 15W Retrofit LED
or
G53 4 x 15W Retrofit LED + GU5,3 1 x 8W Retrofit LED
RGB 660lm

Materials (diffuser / structure): Borosilicate blown
glass / polished steel

Color finishes

Diffuser: Transparent

Structure: Polished steel

Note: GU5,3 LED with RGB + Remote control (usable
until 5m)



Ether S

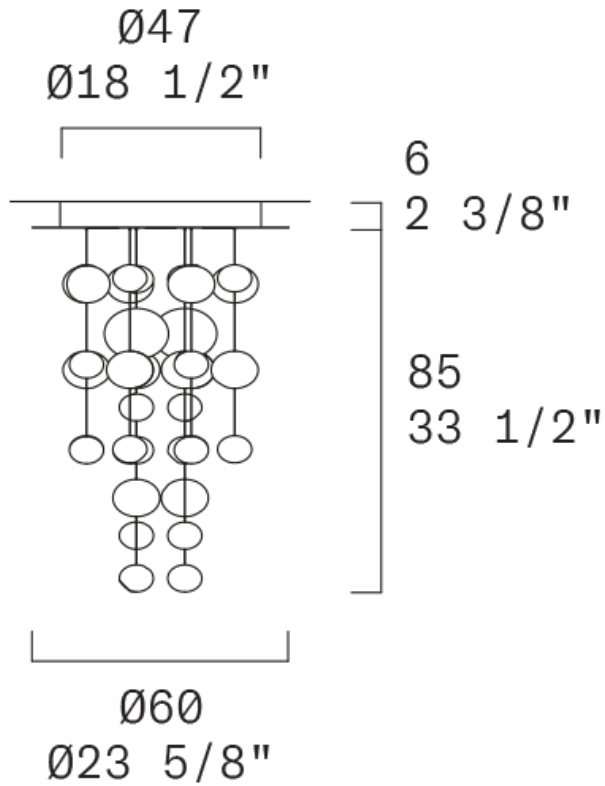

Ether S 50

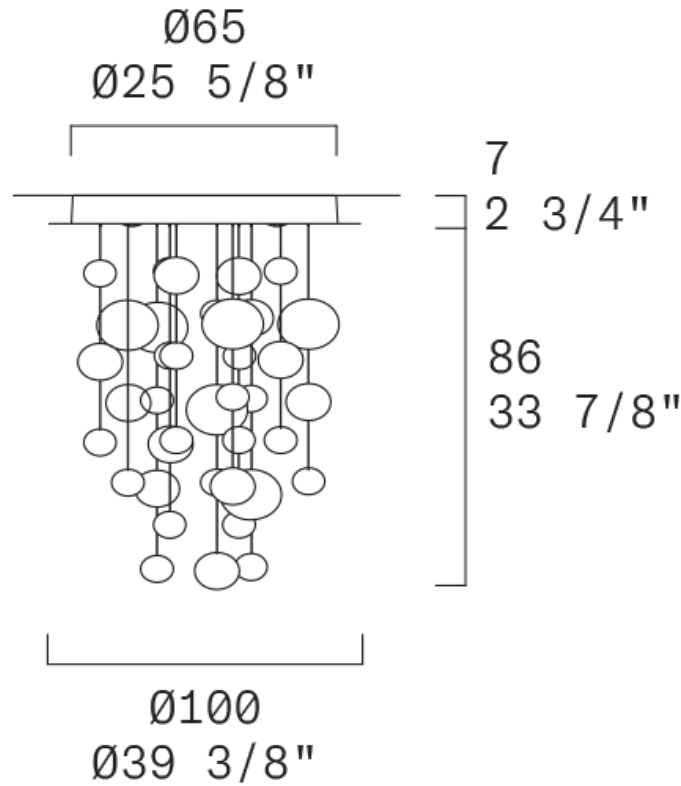

Ether S 90

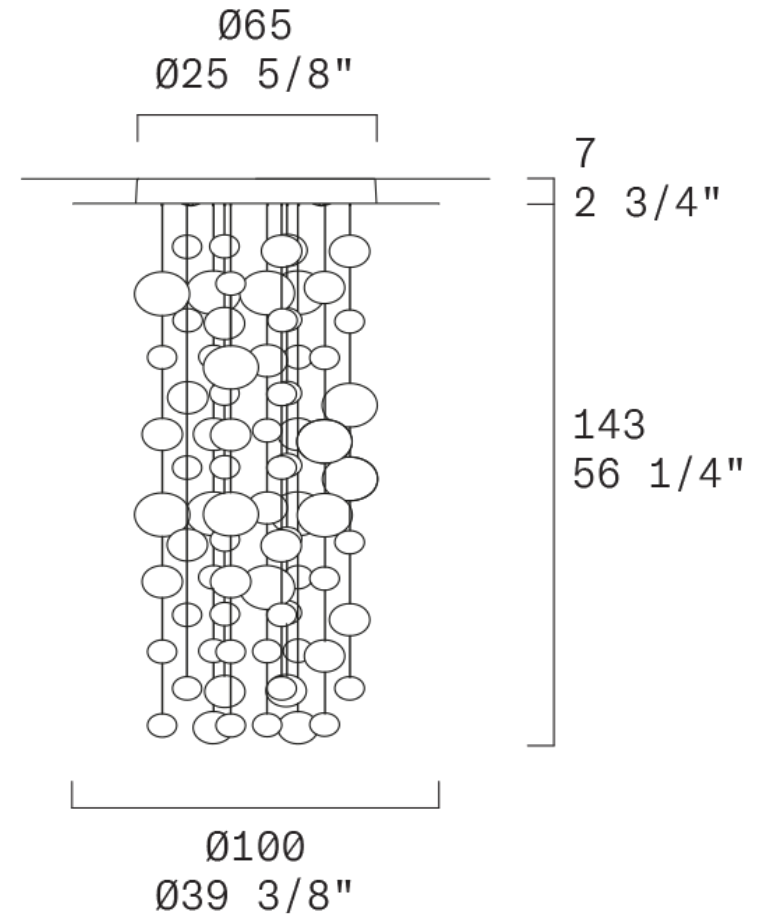

LEUCOS®

You spot it from afar



LEUCOS®

You spot it from afar



LEUCOS®

You spot it from afar



LEUCOS®

You spot it from afar



LEUCOS®

You spot it from afar

Ether custom projects

LEUCOS[®]

You spot it from afar



Mix Restaurant | PRODUCT Ether | DESIGNER Patrick Jouin | Las Vegas, USA

LEUCOS®

You spot it from afar



LEUCOS[®]

You spot it from afar



HOTEL PLAZA | PRODUCT Ether | DESIGNER Patrick Jouin | Abano Terme (Padova), ITALY

LEUCOS®

You spot it from afar



LEUCOS®

You spot it from afar



Bodegas Alion of Penafiel | PRODUCT Ether | DESIGNER Patrick Jouin | Valladolid, Spain



LEUCOS®

You spot it from afar



Wellness Saentispark Abtwil | PRODUCT Ether | DESIGNER Patrick Jouin | Switzerland

LEUCOS®

You spot it from afar



Du Gil's Luonge Bar | PRODUCT Ether | DESIGNER Patrick Jouin | Dubrovnik, Croatia

LEUCOS®

You spot it from afar



LEUCOS®

You spot it from afar



PARK HYATT HOTEL | PRODUCT Ether | DESIGNER Patrick Jouin | Milan, ITALY

LEUCOS[®]

You spot it from afar

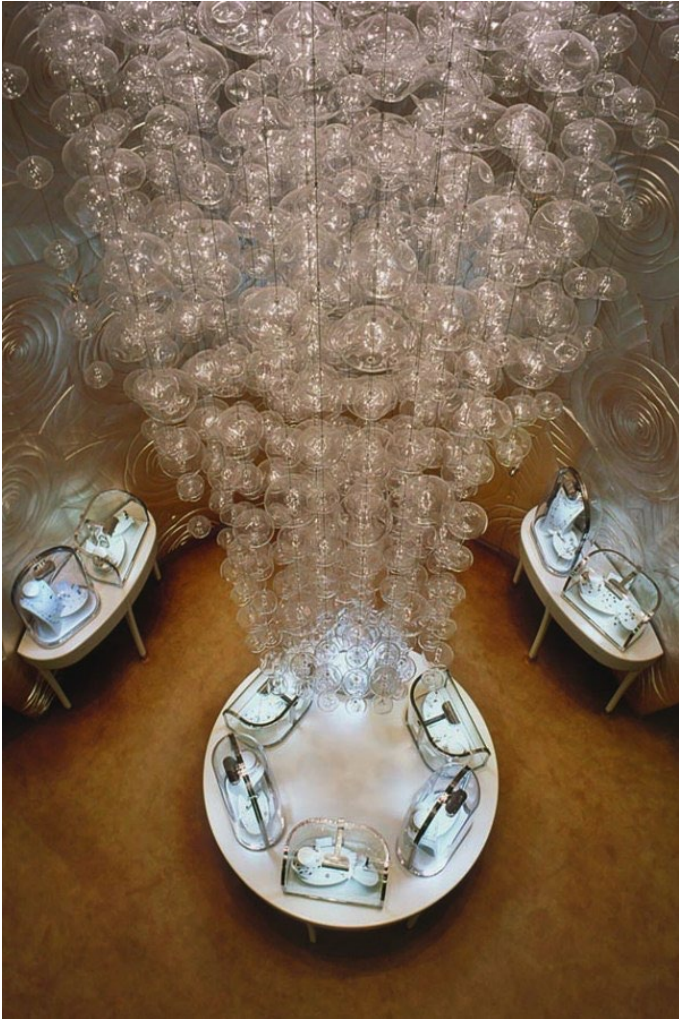

VAN CLEEF & ARPELS | PRODUCT Ether | DESIGNER Patrick Jouin | ARCHITECTS Jouin Mancu Studio | CREDIT Eric Laignel | Paris, FRANCE

Bespoke products - capabilities

Van Cleef & Arpels – Hong Kong (China)

LEUCOS®

You spot it from afar

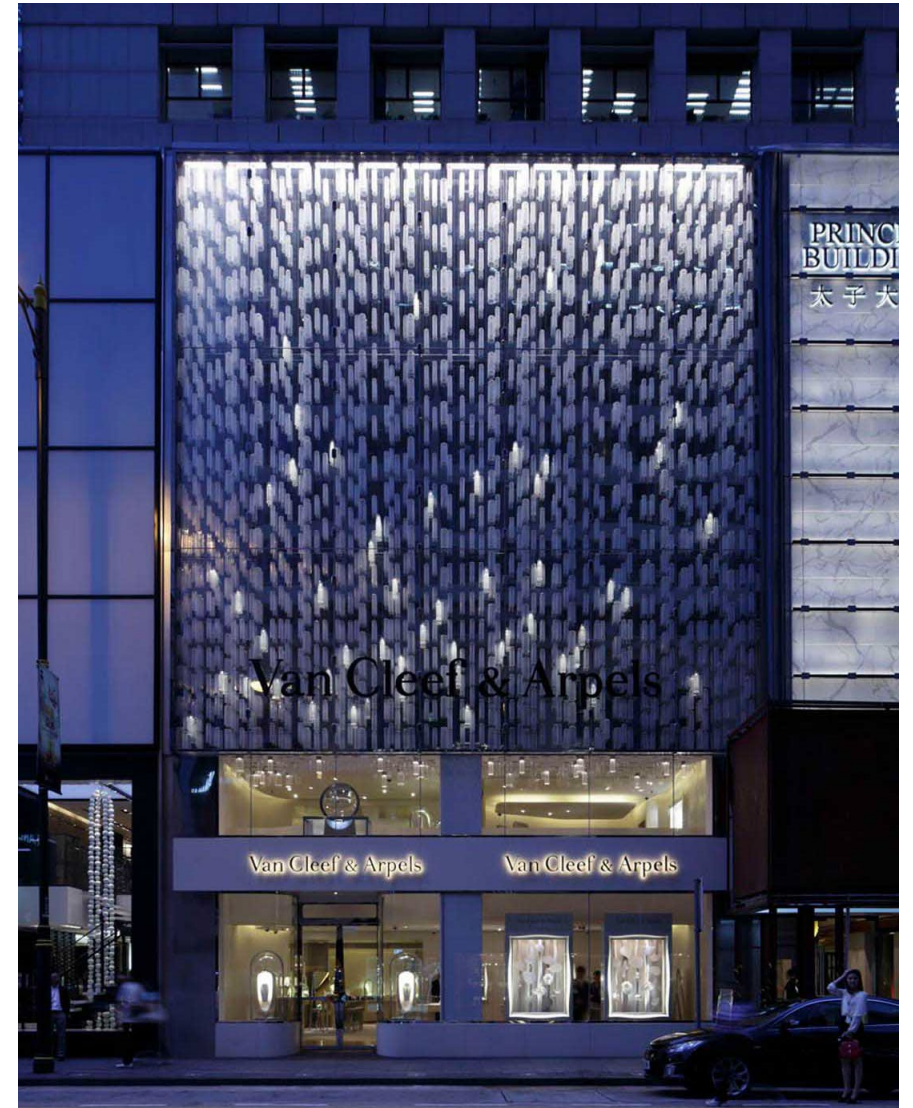

Van Cleef & Arpels | PRODUCT Reed | DESIGNER Patrick Jouin | Hong Kong, China

LEUCOS[®]

You spot it from afar



LEUCOS®

You spot it from afar

F+T+3 – Mogliano Veneto (TV - Italy)

LEUCOS®

You spot it from afar



LEUCOS®

You spot it from afar



LEUCOS®

You spot it from afar



LEUCOS®

You spot it from afar



LEUCOS®

LEVI restaurant - Copenhagen

LEUCOS®

You spot it from afar



LEUCOS®

You spot it from afar



LEUCOS®

You spot it from afar



LEUCOS®

You spot it from afar



LEUCOS®

You spot it from afar



SOLECO